

# HP Integrity server solutions for Business Intelligence

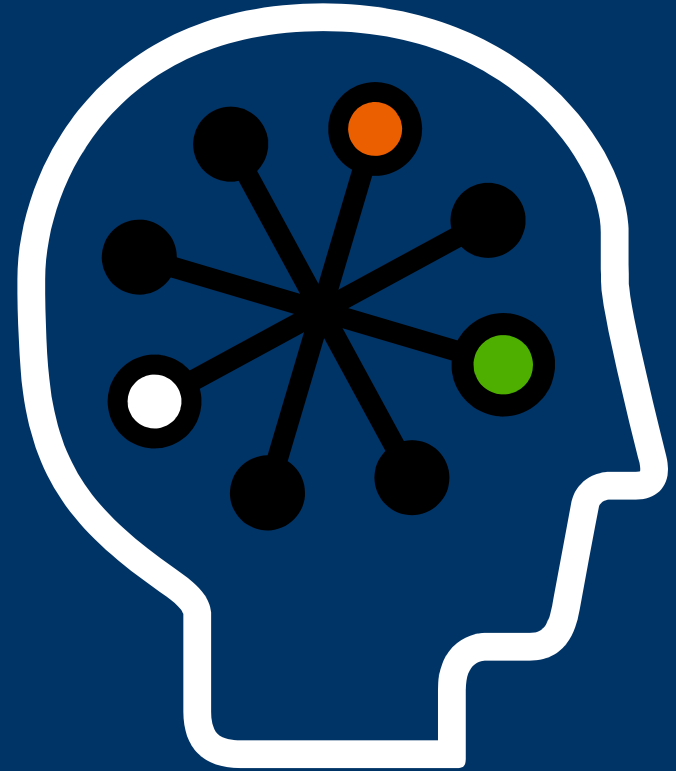

# Implementing a BI Infrastructure

- **Why HP for Microsoft BI**
- Leveraging HP Integrity Servers for a scalable BI environment
- Implementing a BI Architecture with HP Integrity Servers
- Proven customer successes
- Conclusion



# HP Microsoft alliance



- 28,000+ Microsoft-trained professionals
- 3,600+ with highest levels of certification as engineers and developers of Microsoft technologies
- HP has 44% EMEA Microsoft Market
- Only Microsoft partner to be named Microsoft's "Global Enterprise Partner of the Year" 3 times (once as Compaq in 2000, twice as HP in 2003 and 2005)
- HP Services to manage, operate, and administer the [www.microsoft.com](http://www.microsoft.com) infrastructure and to provide worldwide help desk and call center support to 61,000 Microsoft employees in 68 countries



# HP SQL Server solutions for mission critical needs

Now offering a complete SQL Server solution stack

\* **HP Infrastructure:** HP Integrity and ProLiant servers, HP Storage

\* **HP OEM Windows Server 2003 and 2008** for Integrity

\* **HP OEM SQL Server 2005 and 2008** for Integrity

\* **HP Database BI Consulting Services, HP SQL Server Installation and Startup Service**

\* **HP Support offerings** that include HW, OE, and Application (SQL Server) support

- Further demonstrates the strength of the Microsoft and HP partnership for SQL Server on Integrity solutions
  - **HP is the only vendor to OEM SQL Server Enterprise Edition**



# Unmatched HP/Microsoft partnership

- 20+-year HP-Microsoft partnership with nearly a decade of joint development on Itanium® solutions
- Joint Engineering to deliver robust Windows Itanium solution
  - Core enablement of OS across all Integrity platforms
  - Co-development of new features for further scale-up of Windows in the enterprise
  - Microsoft's 64-bit Itanium development platform
  - Influence Microsoft roadmap to benefit of Integrity customers
- SQL Server Performance and Scalability
  - Work with MS SQL Server team to ensure optimum scalability and performance with SQL Server 2008 on Integrity
  - Improve scalability of SQL Server add-ons like Analysis Services and Integration Services
  - Assist with Proof of Concepts that occur in the MS Enterprise Engineering Center (EEC)
- Three-time Microsoft "Global Enterprise Partner of the Year"



# HP's BI strategy

Best BI  
Infrastructure



Proven  
Expertise

Best Partnering  
Approach and  
Ecosystem

# HP Integrity and SQL Business Intelligence strategy

Providing business insights to all employees leading to better, faster, more relevant decisions on business critical architecture

- Complete and integrated performance management offering.
- Pervasive delivery of intelligence through Microsoft Office.
- Business critical RAS and best in class TCO



# Microsoft Business Intelligence Stack

One integrated, end-to-end solution

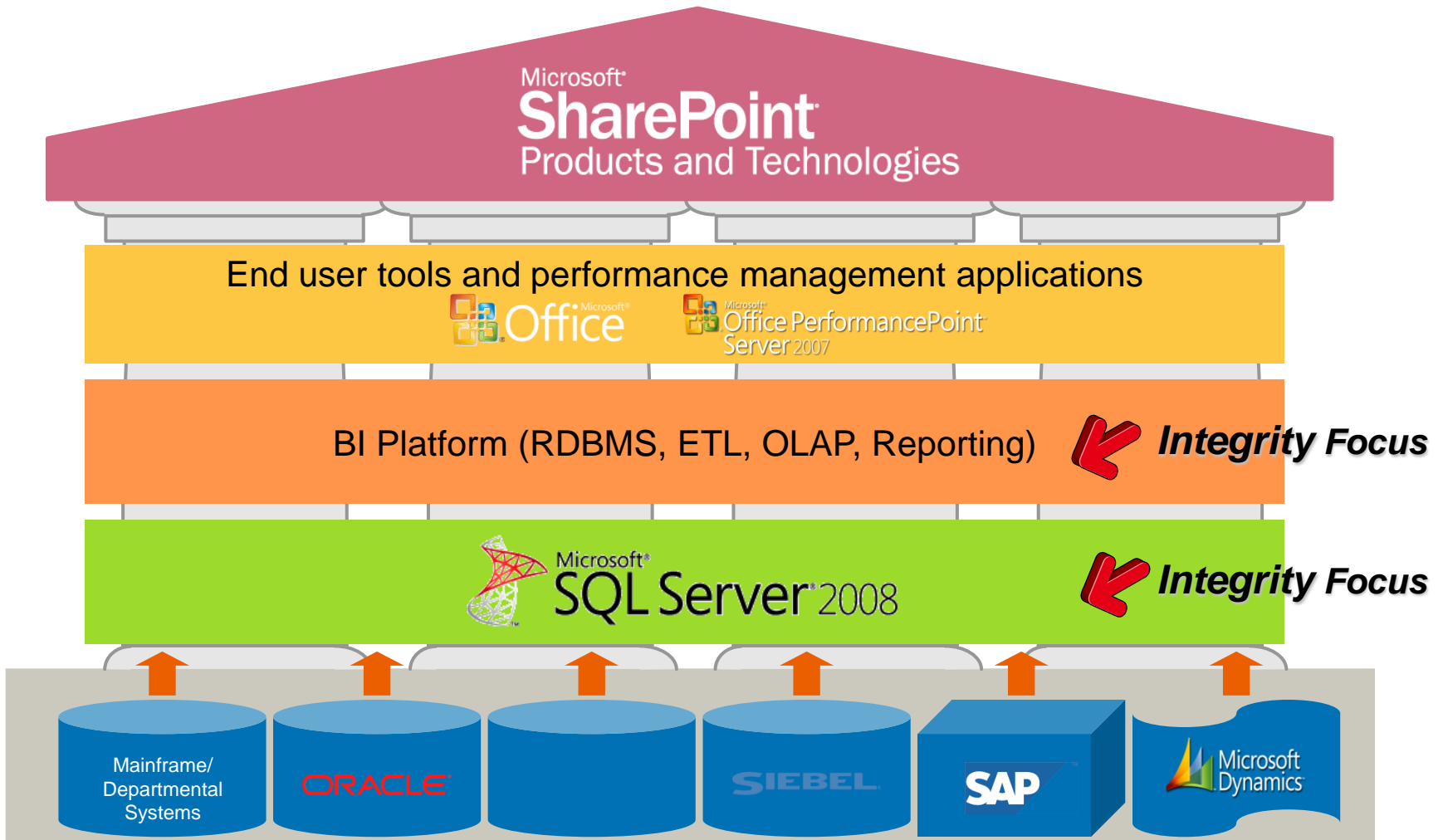

# Cost-effective BI to drive data to every corner of your business

Flexibility for analytics with SQL Server and Integrity servers

- Higher performance and scalability to deliver additional services and analyze usage data
- Business intelligence solution to support custom queries while reducing query time from minutes to seconds
- Superb scalability for growth and to support different types of analysis
- Data mining tools to enable companies to pinpoint most profitable accounts



# Overcoming BI platform limits with SQL Server and HP Integrity servers

Ideal for memory-intensive applications

It's about capabilities...

- Scalability to cope with anticipated increases in the number of users
- Performance to improve response times
- Availability to reduce IT complexity and costs and streamline traditional business functions



# Business Intelligence challenges today

Business data is distributed across the enterprise

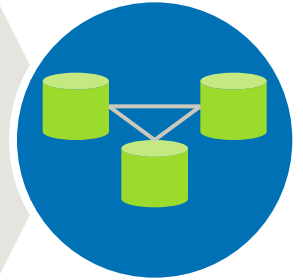

Relevant information on business performance does not span across the enterprise



Actionable insight isn't easily accessible to everyone who needs it



# Every customer's challenge

Legacy applications + data marts = chaos

Enterprise data warehouse = order

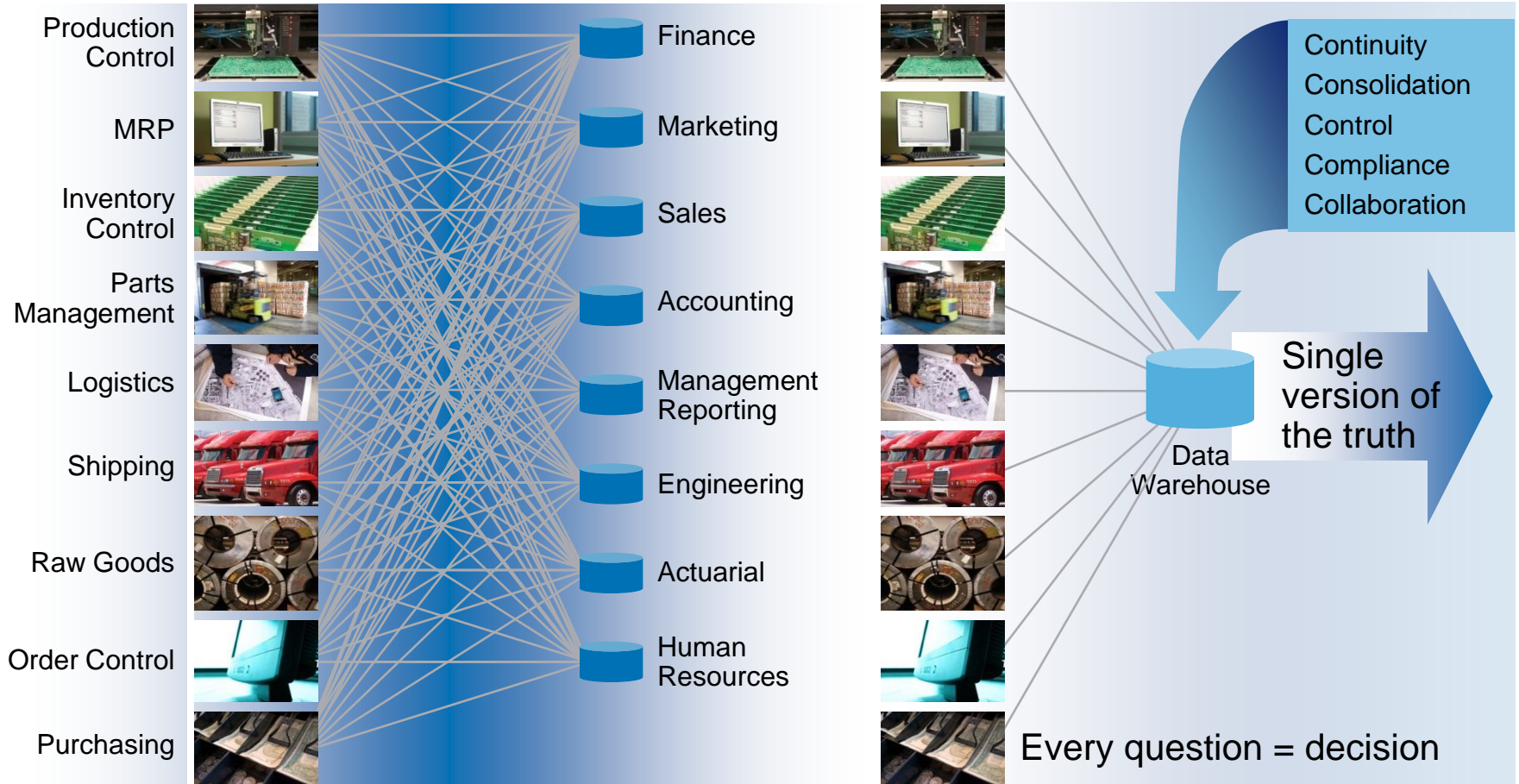

# The four challenges to successful transition

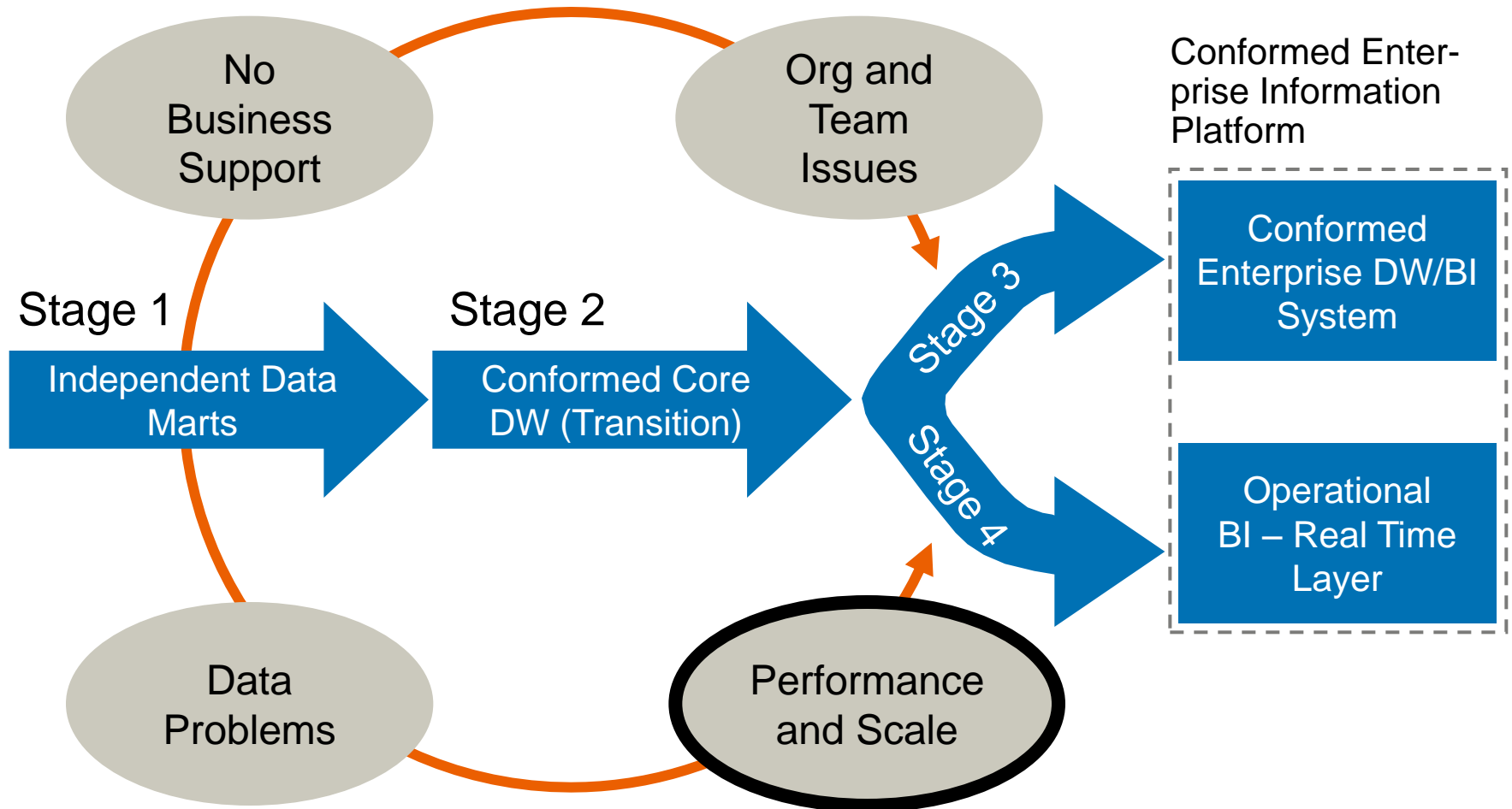

# Implementing a BI Infrastructure

- Why HP for Microsoft BI
- Leveraging HP Integrity Servers for a scalable BI environment
- Implementing a BI Architecture with HP Integrity Servers
- Proven customer successes
- Conclusion



# HP Integrity – trusted expertise, proven solutions for enterprise Windows

Business-critical capabilities for your most demanding workloads

**ALWAYS  
SCALABLE**



**ALWAYS  
AVAILABLE**



**COMPELLING  
TOTAL COST  
OF OWNERSHIP**



**Unmatched HP/Microsoft Partnership**

Leading Windows scalability and performance for most demanding workloads

Mainframe-level Reliability, Availability, and Disaster Tolerance

Extensive manageability portfolio and flexible server utilization for business critical environments

Superior solutions driven by deep enterprise Windows expertise and experience

# Integrity servers with Windows/SQL Server optimized for business-critical workloads

Driving Line of Business applications with a powerful, lower-TCO RISC/mainframe alternative

- Database scale-up
  - OLTP workloads
  - BI/DW workloads
- Server Consolidation
- SAP on SQL Server



# Microsoft on Integrity: Always scalable

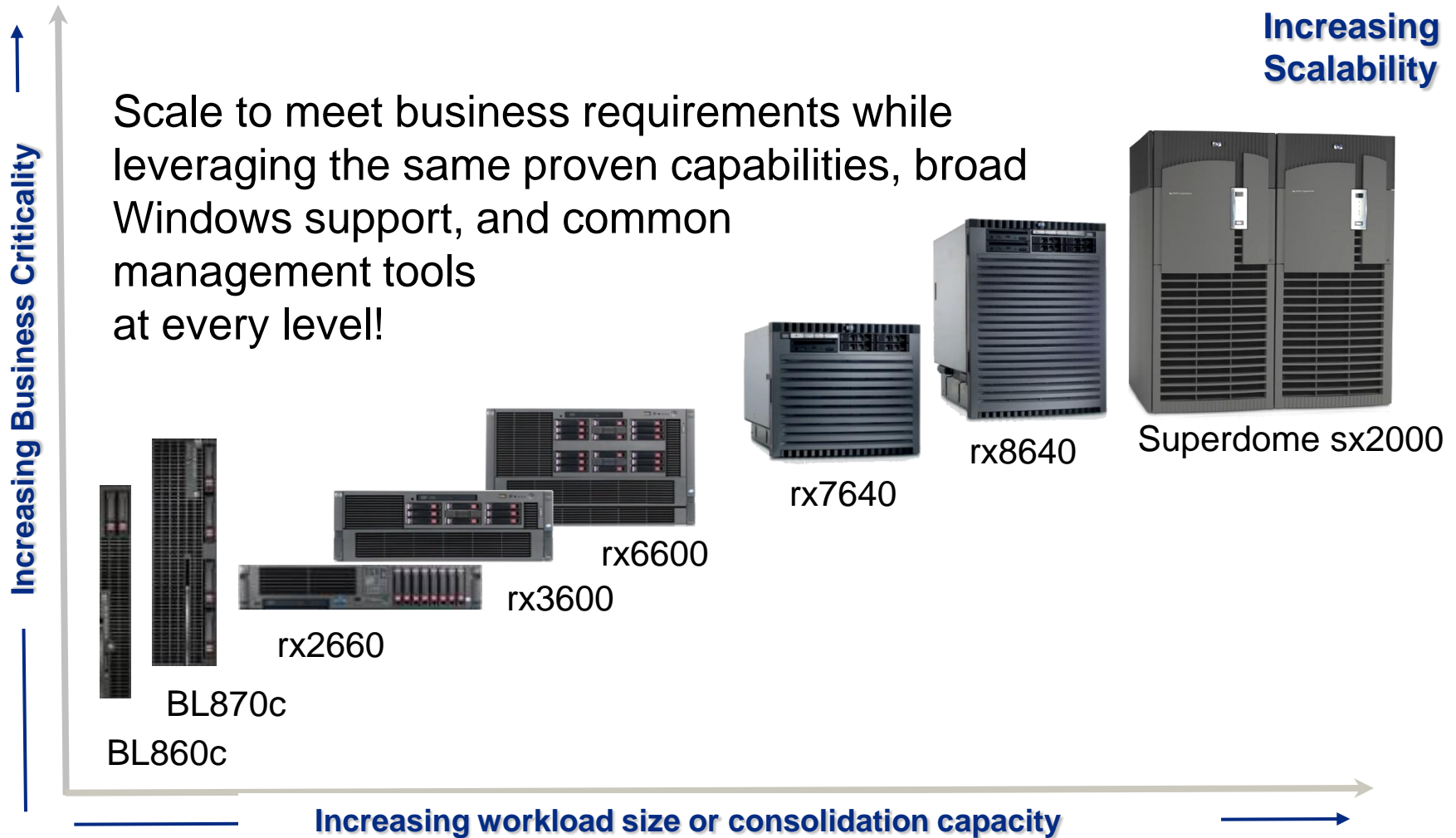

# Itanium<sup>®</sup> Roadmap

Higher Performance  
Better RAS  
Lower TCO



Montvale  
9100 Series

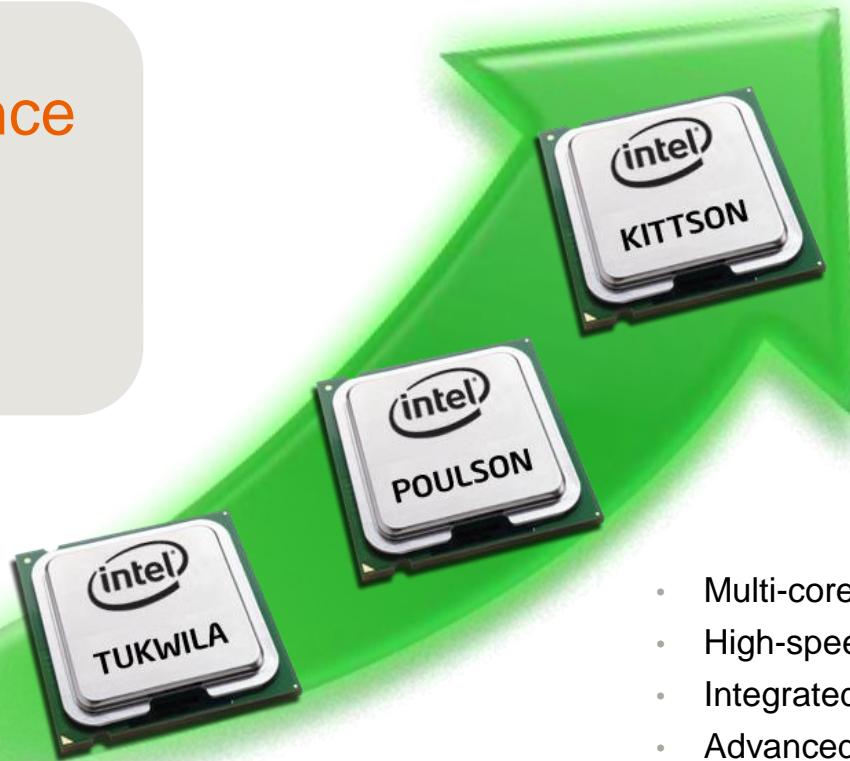

## Future

- Multi-core, massive caches
- High-speed interconnect
- Integrated memory controllers
- Advanced RAS,
- Enhanced virtualization
- Common chipset for design synergies

Increasing Value for the Mission-critical Segment

# Scalable benchmark leadership with Integrity and Windows

OLTP Database	<ul style="list-style-type: none"><li>• #1 Windows TPC-C<sup>1</sup> with Integrity Superdome at 1.2M+ tpmC<sup>1</sup></li></ul>
ERP and SCM	<ul style="list-style-type: none"><li>• #1 32p/64c Windows SAP 2-Tier SD with Integrity Superdome<sup>5</sup></li><li>• #1 16p/32c Windows SAP 2-Tier SD with Integrity Superdome<sup>5</sup></li><li>• #1 Windows SAP 3-tier SD with Integrity Superdome<sup>5</sup></li></ul>
BI and Data Analytics/OLAP	<ul style="list-style-type: none"><li>• #1 Windows 10TB TPC-H with Integrity Superdome and SQL Server 2008<sup>2</sup></li><li>• #1 32p/64c Windows 3TB TPC-H with Integrity Superdome<sup>8</sup> (SQL Server 2005)</li><li>• #1 16p/32c Windows 3TB TPC-H with Integrity rx8640<sup>7</sup> (Oracle)</li><li>• #1 16p/32c Windows 1TB TPC-H with Integrity rx8640<sup>6</sup> (SQL Server 2005)</li></ul>

<sup>1</sup> HP Superdome with Microsoft SQL Server 2005 (SP1), 1,231,433 tpmC @ \$4.82/tpmC, available 6/05/06. See [www.tpc.org](http://www.tpc.org).

<sup>2</sup> HP Integrity Superdome server with 32 Intel® Itanium® 9140n processors and SQL Server 2008 Enterprise Edition and Windows Server 2008 for Itanium-based systems, 63,650.9 QphH @ \$38.54/QphH, available 8/30/08. See [www.tpc.org](http://www.tpc.org).

<sup>5</sup> For full details on SAP benchmarks, see [www.sap.com/benchmark](http://www.sap.com/benchmark).

<sup>6</sup> HP rx8640 with Microsoft SQL Server 2005 (SP1), 33,488 QphH @ \$27.00/QphH, available 10/06. See [www.tpc.org](http://www.tpc.org).

<sup>6</sup> HP rx8640 with Microsoft SQL Server 2005 (SP1), 33,488 QphH @ \$27.00/QphH, available 10/06. See [www.tpc.org](http://www.tpc.org).

<sup>7</sup> HP rx8640 Integrity server running Oracle 10gR2 Enterprise Edition with partitioning on Windows Server 2003 Data Center Edition SP1, 37,813 QphH @ \$38.00/QphH, available 5/14/07. See [www.tpc.org](http://www.tpc.org).

<sup>8</sup> HP Integrity Superdome server running SQL Server 2005 Enterprise Edition SP2 on Windows Server 2003 Datacenter Edition SP1, 60,359 QphH @ \$32.60/QphH, available 5/21/07. See [www.tpc.org](http://www.tpc.org).

All results and comparisons as of 11/04/08



# HP Integrity Superdome takes SQL Server to new heights with 10TB TPC-H record result

- #1 10TB benchmark demonstrates outstanding scalability and BI performance with Integrity and Microsoft® SQL Server 2008
- Breakthrough performance of 63,650.9 QphH at 10TB with Windows Server 2008 and SQL Server 2008 on an HP Integrity server — the first 10TB TPC-H SQL Server result ever published
- Strong performance and business critical RAS features of HP Integrity servers help launch SQL Server 2008 into upper quadrant of enterprise data warehousing market
- Solid price/performance of \$38.54/QphH

Top Windows 10TB TPC-H result on HP Integrity Superdome Server with 32 Intel® Itanium® 9140n processors and SQL Server 2008 and Windows Server 2008 for Itanium-based systems

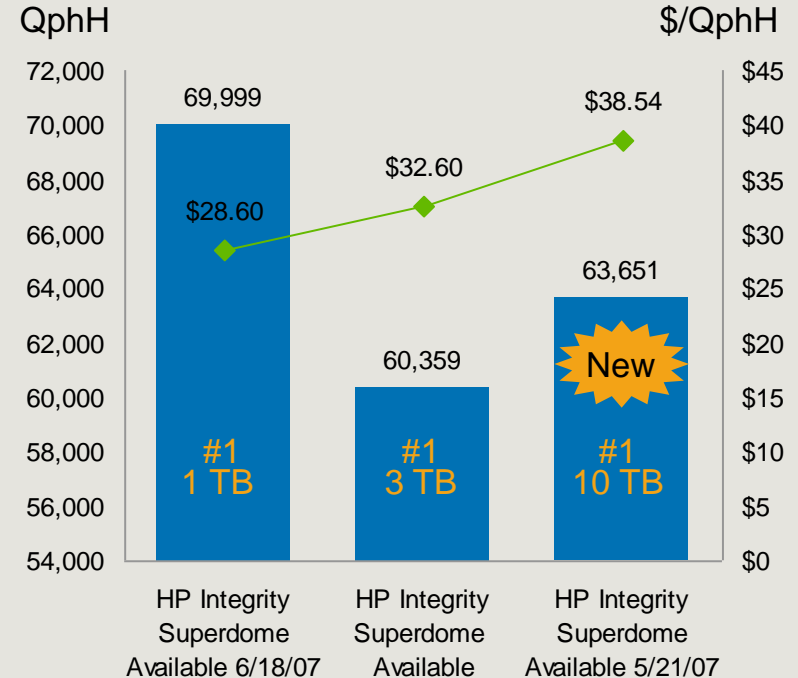

Note: Data as of 2/27/08. See complete results at [www.tpc.org](http://www.tpc.org)



# Scalability leadership with announced future support for 256 logical processors

Room to grow for greater investment protection

- Microsoft announced future support for 256 logical processors
  - Windows Server 2008 R2
  - Next SQL Server release (Kilimanjaro)
- In another scalability “first”, HP and Microsoft demonstrated 256 logical processors running on Superdome onstage at WinHEC (11/08)
- The increased Windows Server/SQL Server scalability takes advantage of HP Integrity Superdome’s current ability to run up to 128 cores/256 threads – now in a single Window partition
- HP Integrity customers win with the ability to scale up to ever more massive, mission-critical SQL databases

# Integrity Superdome w/128 cores/256 threads running Windows Server 2008 R2 and next-gen SQL Server (Kilimanjaro)

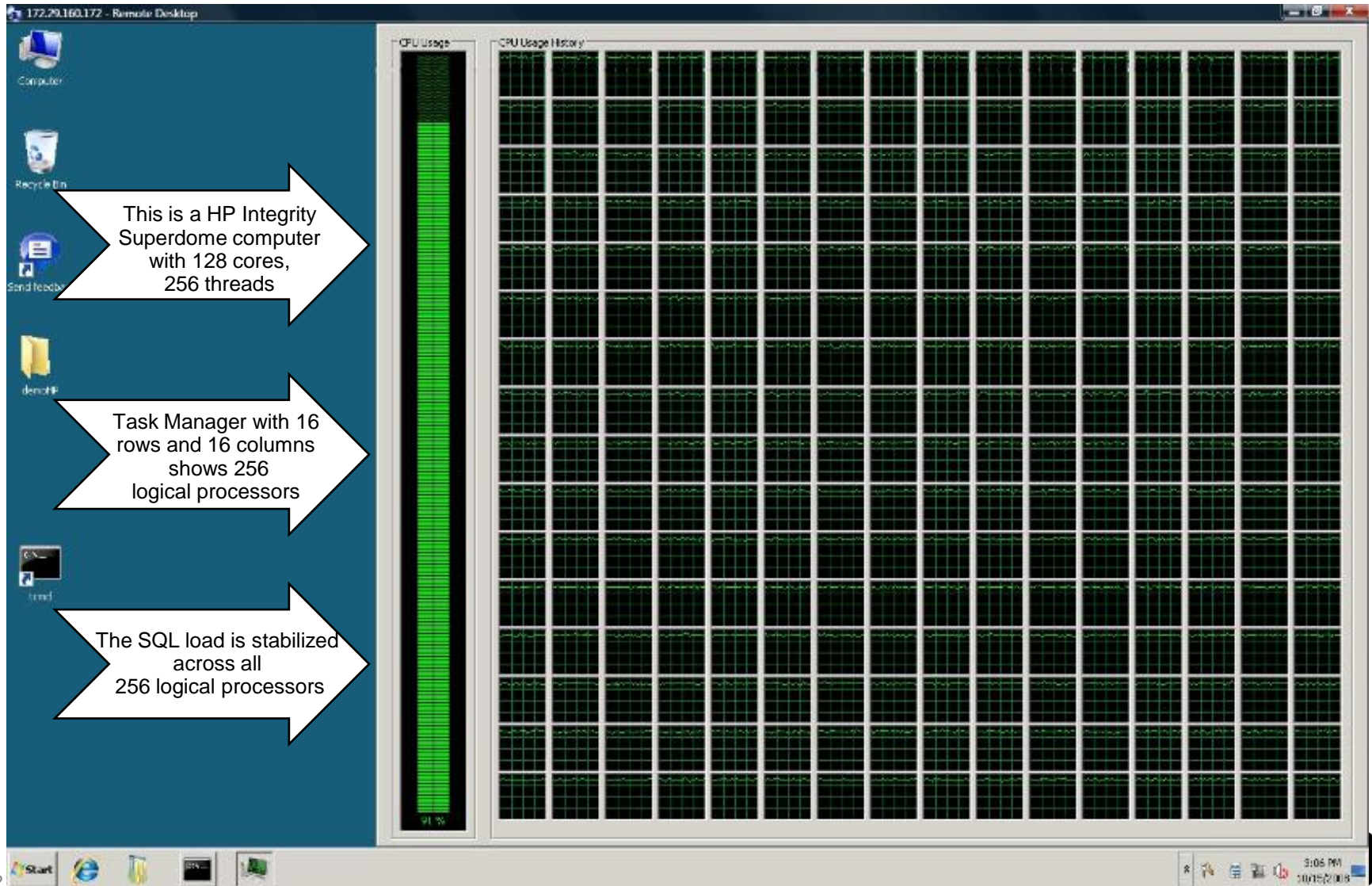

# High availability starts at the core of Windows-based HP Integrity servers



# Integrity hardware RAS features at-a-glance

## Cellular System Advanced RAS Features

### Memory

Double-chip spare & ECC

Address/control bus parity

Double-wipe connectors

Dynamic Memory Resiliency with automatic memory scrubbing

### Processors

1-bit ECC & 2-bit detection on processor caches

1-bit ECC on all processor address/data paths

- Per Processor power supplies for de-allocation (Superdome)
- Per processor 'smart fans' for increased processor reliability

### Infrastructure

Redundant and hot-swap power supplies with dual grid support (Uptime Institute Certified)

Out-of-band management, Firmware updates, remote power control, health monitoring, remote console, and event logging

#### Cellular System Advanced RAS Features

- Hard partitioning with precise error isolation allows concurrent operation & maintenance
- Hot-swap service processor (SP) & system tolerance to SP failures (Superdome)
- Redundant crossbar backplane DC converters (hot-swappable for Integrity Superdome)
- 'Spare Wire' recovery on communication links (Cell-to-cell, Cell-to-IO)
- Redundant DC power conversion for key subsystems

### Chipsets

HP 's Proprietary CECs have highest performance and reliable of any on the market

### I/O

Hardware instantiated Hot-Plug PCI

Hot-swap disks with optional RAID

Isolated I/O buses give error containment

PCI-X 2.0 ECC & error handling

Dual-path I/O with automated switchover

# Integrity servers ideally suited for large data warehouse system requirements

- Large scalable database platform
  - Maximum number of processors for Windows
  - Large memory capabilities
  - Large processing and I/O capabilities
  - NUMA architecture to provide maximum scalability
  - High performance storage subsystem
  - Enterprise class availability
- Flexible tuning capability
  - Flexibility to run smaller isolated or large hard partitions, and reassign hardware resources as needed.
  - Head room to grow partitions over time.
  - Resource management with WSRM, Processor affinity, Memory allocation, Soft NUMA, Resource Governor, Compression.



# NUMA Platform – Non Uniform Memory Access



**Local Memory Access:** Lowest memory access latencies are achieved when CPU is accessing memory within it's own cell.

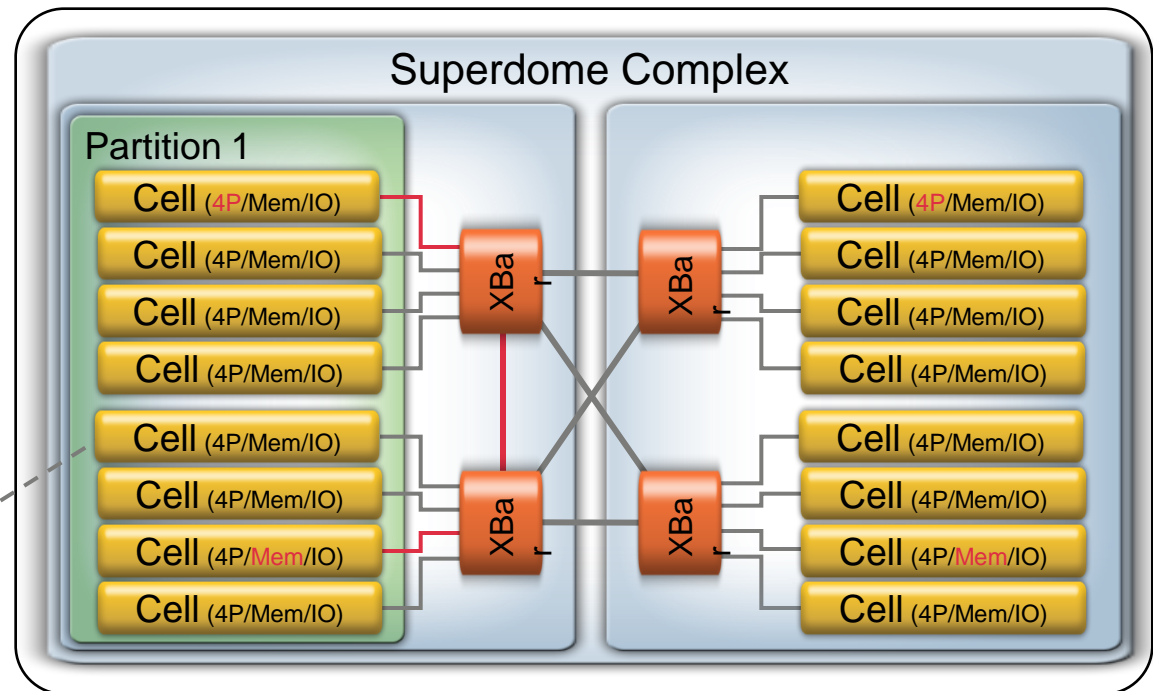
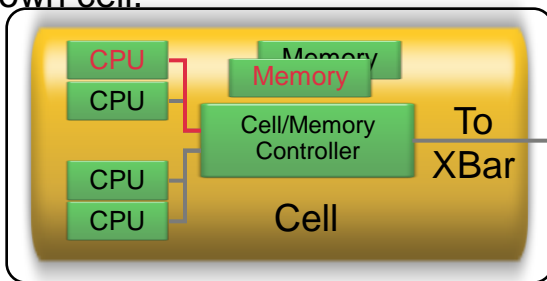

**Remote Memory Access:** Memory access latencies increase when CPU attempts to access memory on a different cell.

# SQL Server and Windows NUMA capabilities

- Windows Server 2003 and 2008 are NUMA aware
  - Windows Server understands the hardware layout
    - Exposes it to NUMA aware applications
    - Schedules and uses resources accordingly
  - Windows has APIs that allows developers to write NUMA aware applications
- SQL leverages the NUMA architecture
  - Allows fast communication between all processors via memory system
  - Results in better resource utilization and ability to process large quantity of data

Windows and SQL NUMA Aware Capabilities enable the massive scalability of Windows Integrity solutions



# Windows Integrity demos

- Multiple Windows Integrity demos are available to show technical details/benefits of the solution:
  - Solution Demo Portal for partners/customers: <http://www.hp.com/go/solutiondemoportal>

## Scalability

- Scalability and Performance of HP Integrity Superdome with Windows and SQL Server
- Future: Increased Scalability with Windows and HP Integrity Superdome: Running 256 LPs
- Large Memory on HP Integrity Server with Windows Server and SQL Server
- Scale up a Windows on HP Integrity partition using Partition Manager

## Resource management

- Resource Management Capabilities with Windows System Resource Manager (WSRM) on Windows Server with SQL Server
- SQL Server CPU Affinity on HP Integrity Server with Windows
- Configuring Soft NUMA with SQL Server on HP Integrity with Windows
- Resource Governor on SQL Server 2008

## SQL Server

- SQL Server 2005 Database Partitioning on Integrity Servers
- Database mirroring with SQL Server 2005 on HP Integrity Server
- Database compression with SQL Server 2008 on HP Integrity Server



# Implementing a BI Infrastructure

- Why HP for Microsoft BI
- Leveraging HP Integrity Servers for a scalable BI environment
- **Implementing a BI Architecture with HP Integrity Servers**
- Proven customer successes
- Conclusion



# Business Intelligence architectures: Scale-in advantage

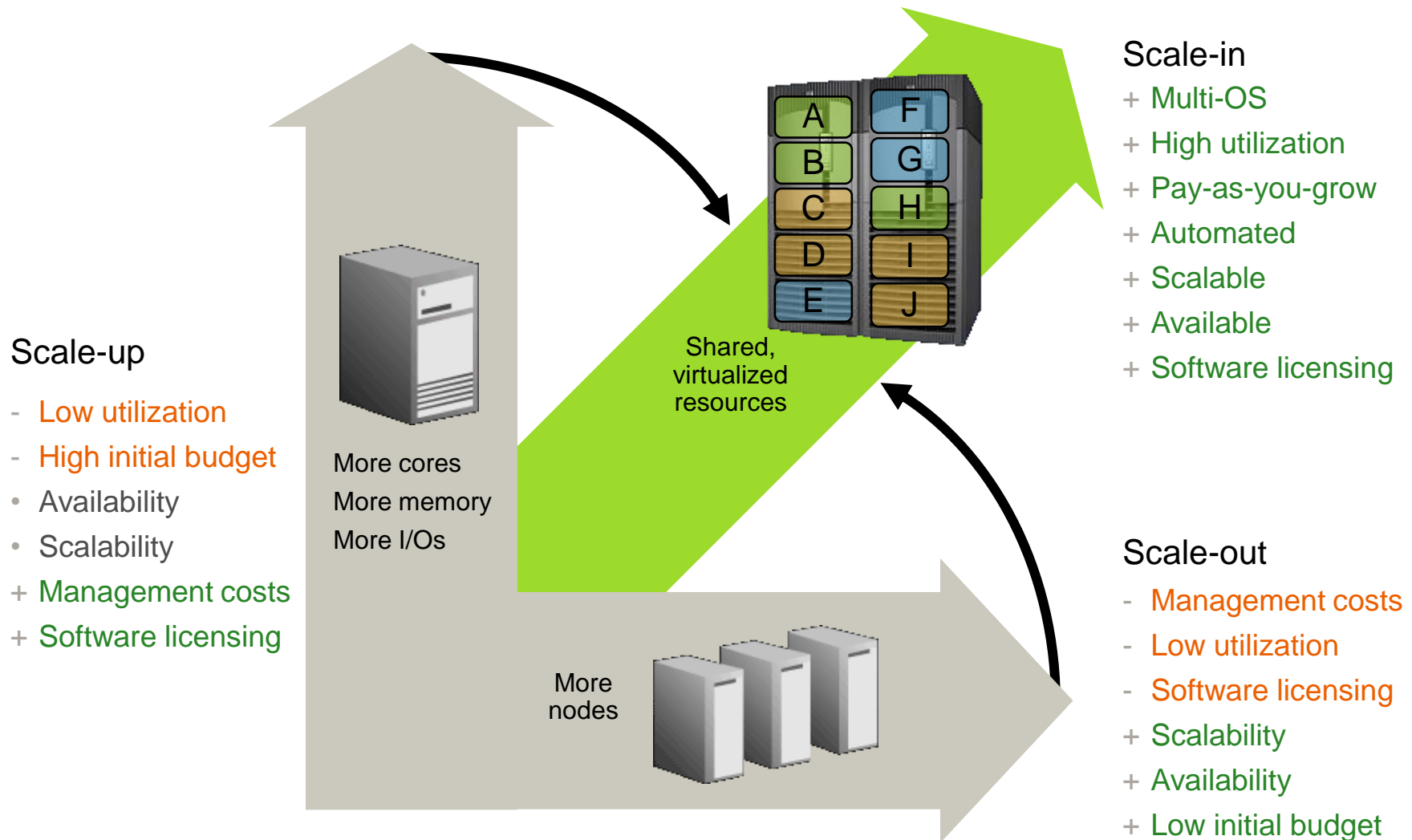

# Server scale-in strategy for BI

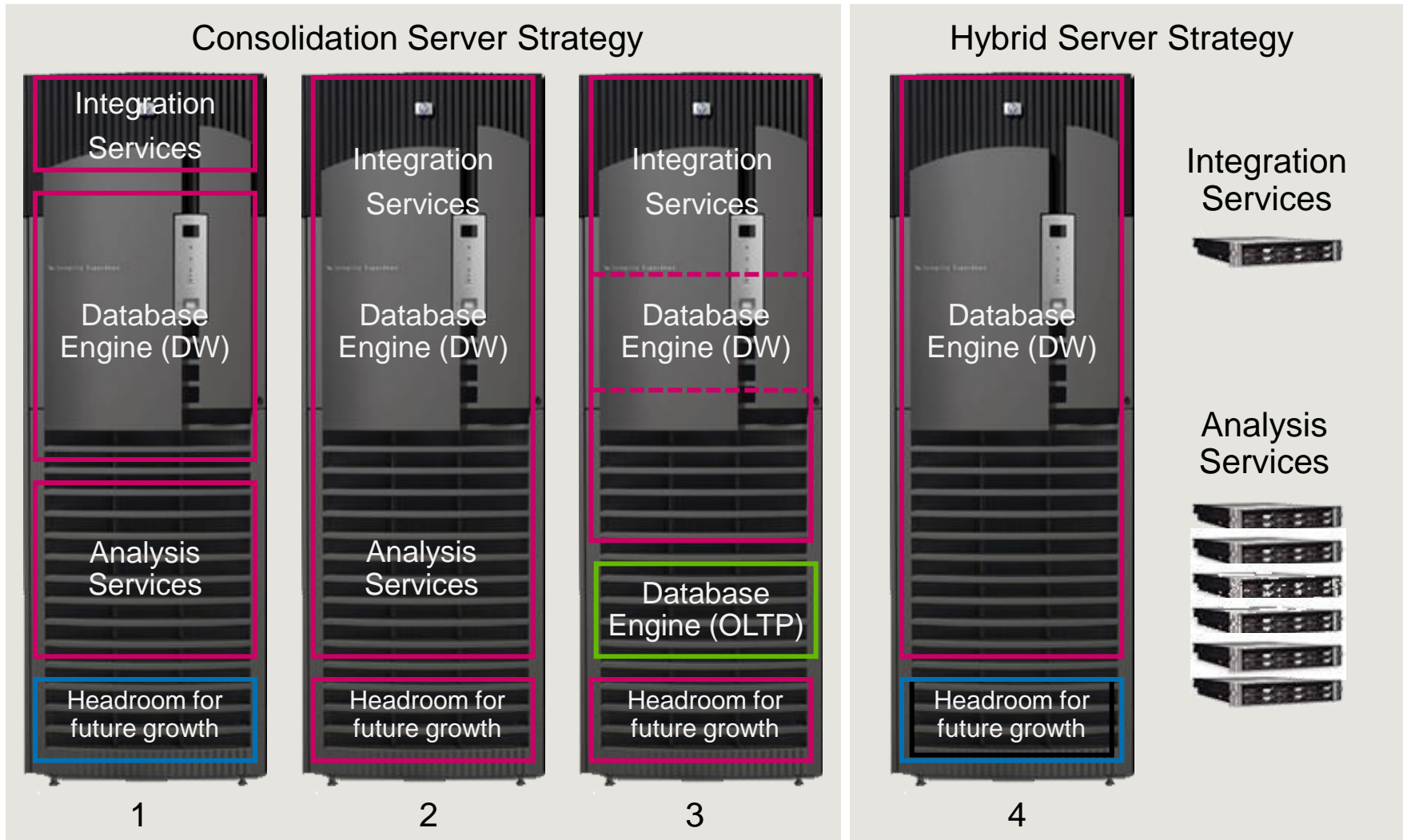

# HP's industry leading BI platform portfolio

- 1 Data Mart
- 2 BI Appliance
- 3 Data Warehouse
- 4 Consolidated BI Ecosystem
- 5 Backup & Recovery

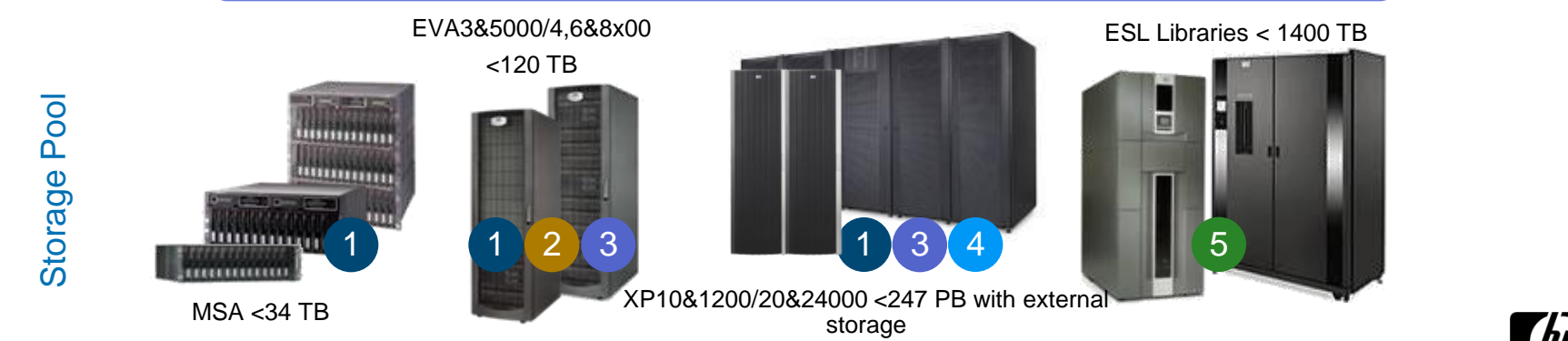
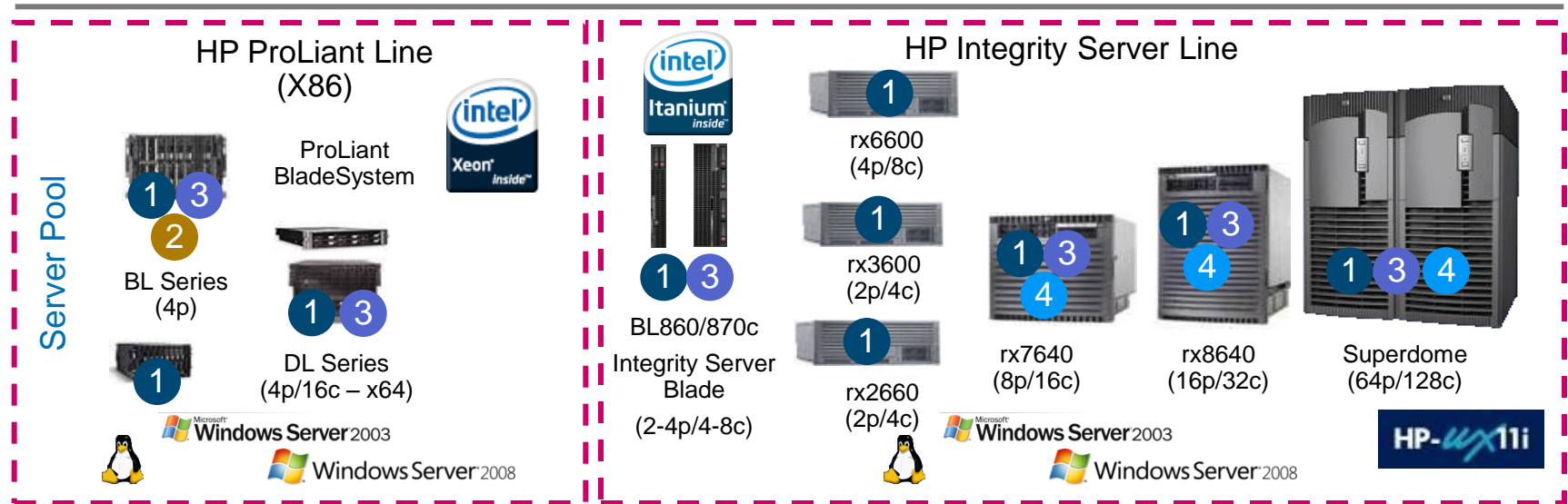

# Reference configurations for the 3 major BI tiers

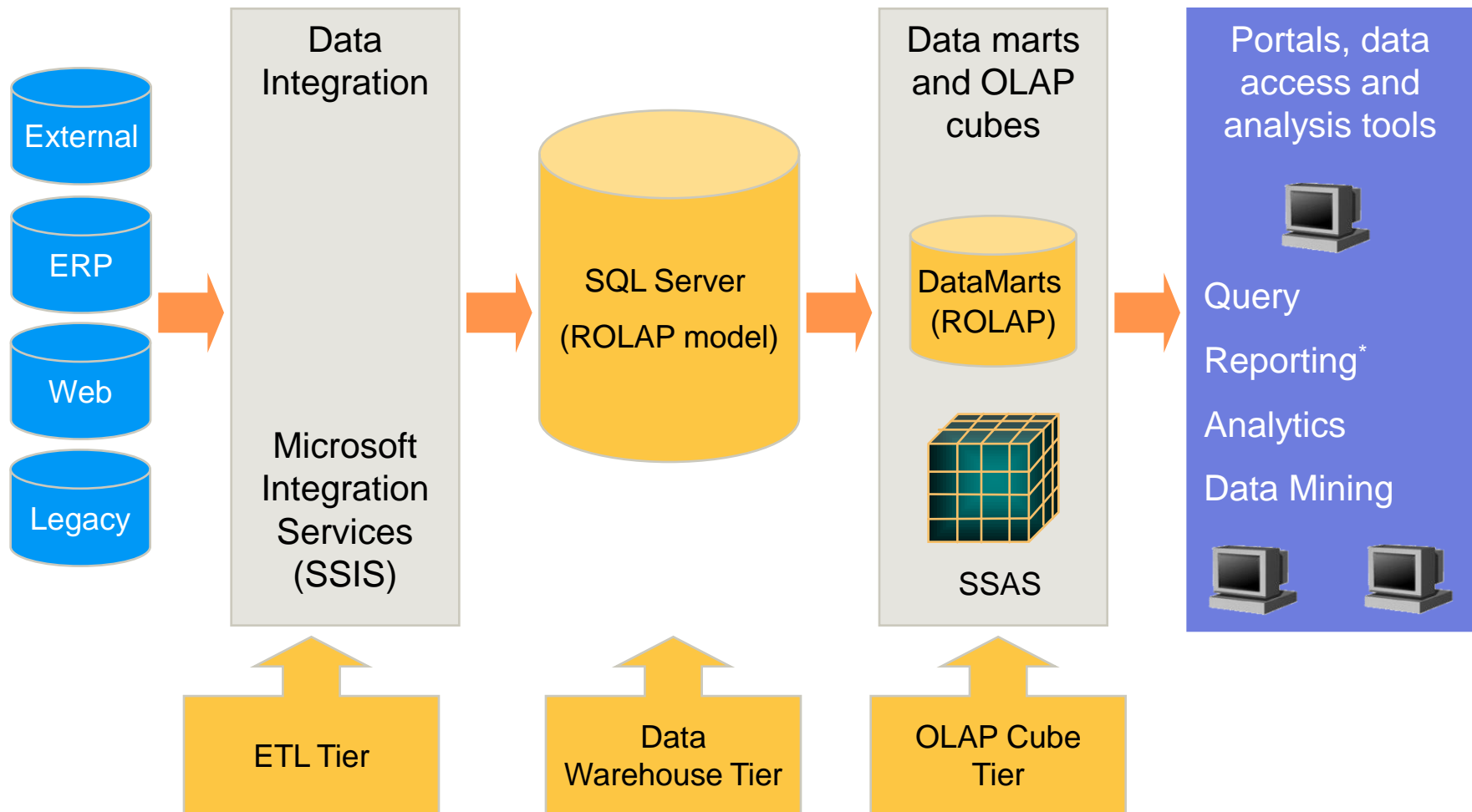

\* Reporting Services main workload is using ROLAP and OLAP queries

# HP Integrity reference configurations for BI

## Reduced time to purchase

- When a LOB wants to purchase a new data warehouse server. Starting with a baseline configuration can make the negotiation time with IT shorter decreasing purchase cycle time

## Reduced time to implement

- The system configurations and how the database should be laid out are described in the reference configuration documentation which can help reduce time to implement

## Reduced risk

- The systems have been designed to produce balanced configurations based on systems performance testing done in HP engineering labs

[http://h20341.www2.hp.com/integrity/downloads/HP\\_BI\\_Integrity%20Flyer\\_022608\\_FINAL.pdf](http://h20341.www2.hp.com/integrity/downloads/HP_BI_Integrity%20Flyer_022608_FINAL.pdf)  
(SQL 2008) <http://h20195.www2.hp.com/V2/GetDocument.aspx?docname=4AA2-2222ENW>  
(SQL 2005) <http://h20195.www2.hp.com/V2/GetDocument.aspx?docname=4AA1-3327ENW>

# Sizing tools

- SQL Server BI sizing tools use “Atomic modeling” algorithms based upon YOUR defined workload.
  - What are the odds that your workload will match our “assumed” workload?
    - Defining your workload to a sizing model is more accurate
  - They are NOT best guess “Reference Configuration Selectors” that is being called a sizing tool

Input Fields	Total # Users	Simple	Medium	Complex	Very Complex
Normal users	21 thru 252	75%	24%	1%	0%
Advanced users	3 – 36	50%	48%	2%	0%
Power users	1 – 12	5%	50%	44%	1%
Realistic response times (secs)		60	600	1,200	3,600
Average think time (secs)		1,800	3,600	5,400	7,200
Estimated number of I/Os per query		Varies depending upon DB size (17K – 342K)	Varies depending upon DB size (21M – 417M)	Varies depending upon DB size (56M – 1,112B)	Varies depending upon DB size (700M – 14B)

# Reference configurations and sizing tools - why should I care?

- Sizing tools vs. Reference Configurations
- SQL Server BI sizing tools use “Atomic modeling” algorithms based upon YOUR defined workload.
  - What are the odds that your workload will match our “assumed” workload ?
    - Defining your workload to a sizing model is more accurate
  - They are NOT best guess “Reference Configuration Selectors” that is being called a sizing tool
- BI Sizing Tools for SQL Server 2005
  - Tier 1) Microsoft Integration Services (ETL)
  - Tier 2) User query workload hitting a SQL Server ROLAP model
  - Tier 3) User query workload hitting Microsoft Analysis Services (OLAP cube)
  - Tier 3a) Build Microsoft Analysis Services (OLAP cube) &

<http://h71019.www7.hp.com/ActiveAnswers/Secure/351481-0-0-0-121.html>

<http://h20195.www2.hp.com/V2/GetDocument.aspx?docname=4AA2-2222ENW>



# HP Services for Windows/SQL Server

Design, build, integrate, manage and evolve

- **Proven experience, recognized expertise and leadership**
  - More than 28,000 Microsoft-trained professionals in over 160 countries
  - Dedicated Information Management C&I practice with 2800 BI consultants
- **Comprehensive portfolio of services**
  - Assessment services for integration, migration, consolidation
  - Global deployment capabilities for onsite installation and start-up services
  - HP technical services for implementations, assessments, analyses, and operations start-up
  - Leading operations management of Windows-based data centers
  - Investment protection with services and support across solution lifecycle



>> HP named Microsoft  
Partner of the Year  
for 4th time



# HP BI expertise and services

- More than 1,300 joint BI customers with Microsoft
- Industry-specific BI solutions incorporating key SQL Server and Microsoft analytic tools
  - Supply Chain Inventory Optimization and Customer Support Analytics
- SQL Server platform migration and consolidation services to reduce TCO
- Migrating Analysis Services for a smooth transition from SQL Server 2000 to SQL Server 2008



# Implementing a BI Infrastructure

- Why HP for Microsoft BI
- Leveraging HP Integrity Servers for a scalable BI environment
- Implementing a BI Architecture with HP Integrity Servers
- Proven customer successes
- Conclusion



# PREMIER Bankcard

## Financial Services, US

Leading credit card provider with managed assets of \$700 million and 2,400 employees

### The HP difference

- Trusted relationship with HP
- Strong partnership between HP and customer's VAR
- Complete ecosystem for business intelligence
- HP Integrity server performance, scalability, reliability



Challenge	Solution	Result
<ul style="list-style-type: none"><li>▪ Build and sustain profitable portfolio of credit card accounts</li><li>▪ Help people reestablish credit and offer them attractive products and services</li><li>▪ Increase performance, availability and scalability of data warehouse</li><li>▪ Give decision makers better performance, more sophisticated tools</li><li>▪ Support 8% annual business growth rate</li></ul>	<ul style="list-style-type: none"><li>▪ Upgrade from x86 to HP Integrity rx5670 and rx8640 (16-way) running Microsoft SQL Server 2005 for mission-critical BI</li><li>▪ HP Integrity rx4640 (4-way) running SAS knowledge base</li><li>▪ Proactive 24 hour support</li><li>▪ HP Enterprise Virtual Array (EVA) expansion and XP24000</li></ul>	<ul style="list-style-type: none"><li>▪ 30-100+% performance improvement</li><li>▪ Queries that took 22 hours now take 45 minutes</li><li>▪ Data mining has enabled company to pinpoint most profitable accounts</li><li>▪ Scales easily to meet rapid business growth – from 6TB to 12TB with Integrity solution</li><li>▪ 99.9% solution availability</li></ul>

# Pechanga Resort & Casino

## Entertainment



Challenge	Approach	Results
<ul style="list-style-type: none"><li>• Consolidate sprawling platform of several hundred servers and &gt;100 different systems for core business functions</li><li>• Make IT more responsive to customers &amp; personnel</li><li>• Implement data warehouse of customer profiles</li><li>• Employ BI to enhance services</li><li>• Improve server mgmt.</li><li>• Support global expansion</li></ul>	<ul style="list-style-type: none"><li>• Deploy 2 HP Integrity rx8640 Servers running Microsoft Windows Server 2003</li><li>• Use Integrity to power a SQL Server 2005 data warehouse as well as the BI and development environments</li><li>• Consolidate systems via hard partitions on a single Integrity server</li><li>• Run ProClarity application on HP ProLiant Servers</li></ul>	<ul style="list-style-type: none"><li>• Comprehensive customer data</li><li>• More astute decision making</li><li>• Improved customer satisfaction and service</li><li>• Greater flexibility to support expansion</li><li>• Stable, reliable platform</li><li>• Efficient server mgmt.</li><li>• Reduced hardware expenditures (due to in-box processor upgrades)</li><li>• Easier system changes</li></ul>

# First American Title Insurance – Insurance Services, North America

Replace Unisys ES7000 systems with HP Integrity Superdome servers running Microsoft SQL Server for core business

Challenge	Approach	Results
<ul style="list-style-type: none"><li>• Attract more customers to grow the business</li><li>• Reduce costs and handle more business by decreasing processing time and streamlining procedures for title and escrow settlement</li><li>• Automate processes to improve business performance and quickly respond to customer needs and market changes</li><li>• Improve productivity of 15,000 employees in 1,300 offices worldwide</li></ul>	<ul style="list-style-type: none"><li>• Replace Unisys ES7000 systems with HP Integrity Superdome servers running Microsoft Windows 2003, Datacenter Edition, Microsoft SQL Server for automated, browser-based FAST Transaction System</li><li>• HP Solution Center for proof of concept, faster deployment</li><li>• HP Consulting and Integration Services, Mission-Critical Support, IT Infrastructure Consulting, HP Customer Support Services</li></ul>	<ul style="list-style-type: none"><li>• Contribute to \$100 million in annual savings due to increased efficiency and reduced processing time</li><li>• By optimizing productivity, First American Title can deliver valuable services to customers</li><li>• Proven path to scale systems enables First American to move from maintenance to expansion</li><li>• Reduced risk, faster deployment</li><li>• Support for ongoing business continuity in 1,300 offices</li></ul>

# Exceptional availability with Windows on Integrity

Greene, Tweed	Achieved “four nines” reliability
Indigo Lighthouse	100% uptime during first year
	99.9% solution availability
Ameren	No unplanned outages since implementation
Finance Committee	Less than 12 minutes per year downtime
St. Petersburg Gaitame	Uninterrupted availability of data
La Lorraine	99.98% availability
RaceO	Continuous operation for a year; no lost transactions

# Real return with Integrity and Windows



33% reduction in TCO



Achieved ROI in three months

PGGM

Reduced IT costs by more than 40%



Will save \$300K in SQL Server licensing

LOGSTOR

Estimate 100% ROI within three years

# Implementing a BI Infrastructure

- Why HP for Microsoft BI
- Leveraging HP Integrity Servers for a scalable BI environment
- Implementing a BI Architecture with HP Integrity Servers
- Proven customer successes
- **Conclusion**



# Key HP Integrity BI take-away's



- Significant savings, exceptional availability and improved flexibility can be achieved through consolidation of data sources or existing datamarts into a single, performance driven, scale-in, easy-to-manage BI environment
- Windows on HP Integrity addresses the performance and manageability challenges for BI
- HP, Microsoft and Intel have a strong engineering and alliance interlock on Business Intelligence

# To learn more on HP Integrity with SQL

- Best practices for highly available HP Integrity servers and Microsoft SQL Server
  - <http://h20195.www2.hp.com/V2/GetDocument.aspx?docname=4AA0-8978ENW>
- HP reference configuration for Business Intelligence (Superdome and others)
  - <http://h20195.www2.hp.com/V2/GetDocument.aspx?docname=4AA0-8979ENW>
  - <http://h20195.www2.hp.com/V2/GetDocument.aspx?docname=4AA1-3327ENW>
- Deploying BI solutions on SQL Server 2005 and HP Integrity servers (Windows Integrity BI Sizer)
  - <http://h71019.www7.hp.com/activeanswers/Secure/351481-0-0-0-121.html>
- Microsoft site for SQL Server 2008
  - <http://www.microsoft.com/sqlserver/2008/en/us/default.aspx>

## Whitepapers

- Scaling Up Your Data Warehouse with SQL Server 2008
  - <http://msdn.microsoft.com/en-us/library/cc719182.aspx>
- Optimizing HP Servers with Microsoft SQL Server 2008
  - <http://h20195.www2.hp.com/V2/GetDocument.aspx?docname=4AA1-7712ENW>
- Best practices for highly available HP Integrity servers and Microsoft SQL Server
  - <http://h20195.www2.hp.com/V2/GetDocument.aspx?docname=4AA0-8978ENW>
- Using SQL Server 2008 Data Compression with HP ProLiant and Integrity servers and HP EVA 8x00
  - <http://h20195.www2.hp.com/V2/GetDocument.aspx?docname=4AA1-8766ENW>



Technology for better business outcomes

